

**Repair  
Parts  
List**

MODEL NUMBER  
MAH21PDAGW

**WASHER  
MAH21 1**

When requesting service or ordering parts, always provide the following information:

- **Product Type**
- **Part Number**
- **Model Number**
- **Part Description**

**MAYTAG**®

©2005 Maytag Services

Section: CONTROL PANEL

MAH21 1 P1

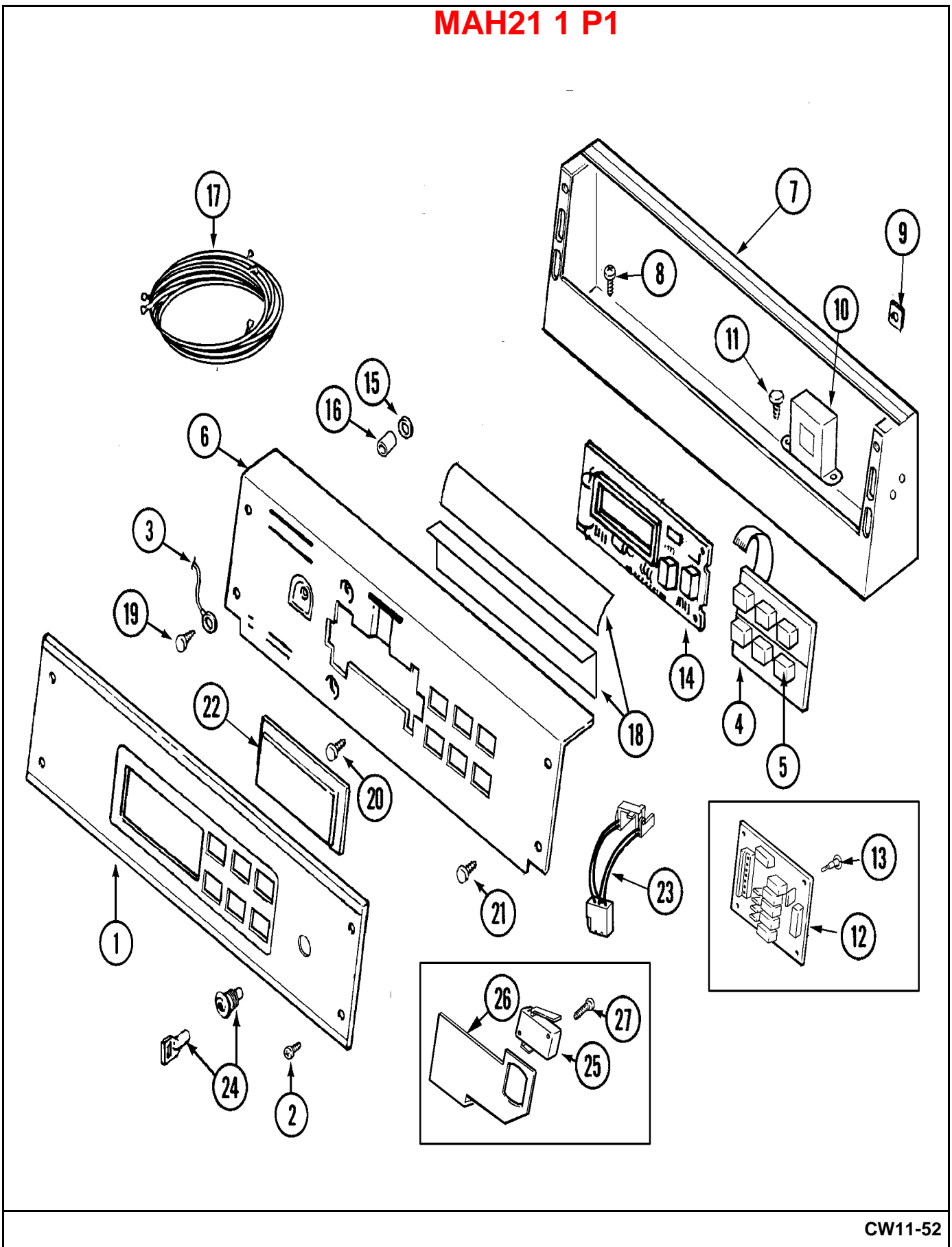

**MAH21 1 P2**

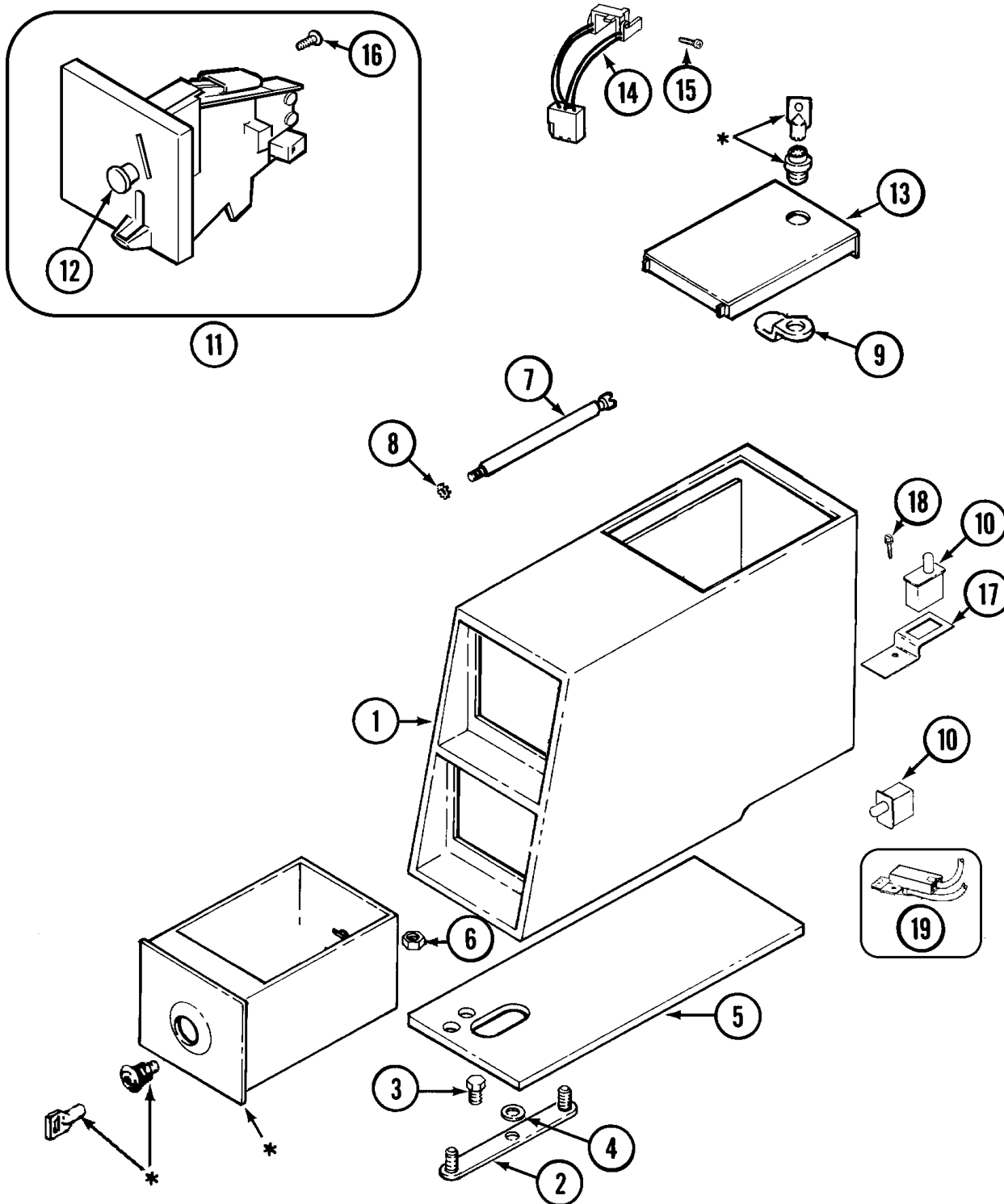

\* CONTACT YOUR COMMERCIAL LAUNDRY DISTRIBUTOR

**MAH21 1 P3**

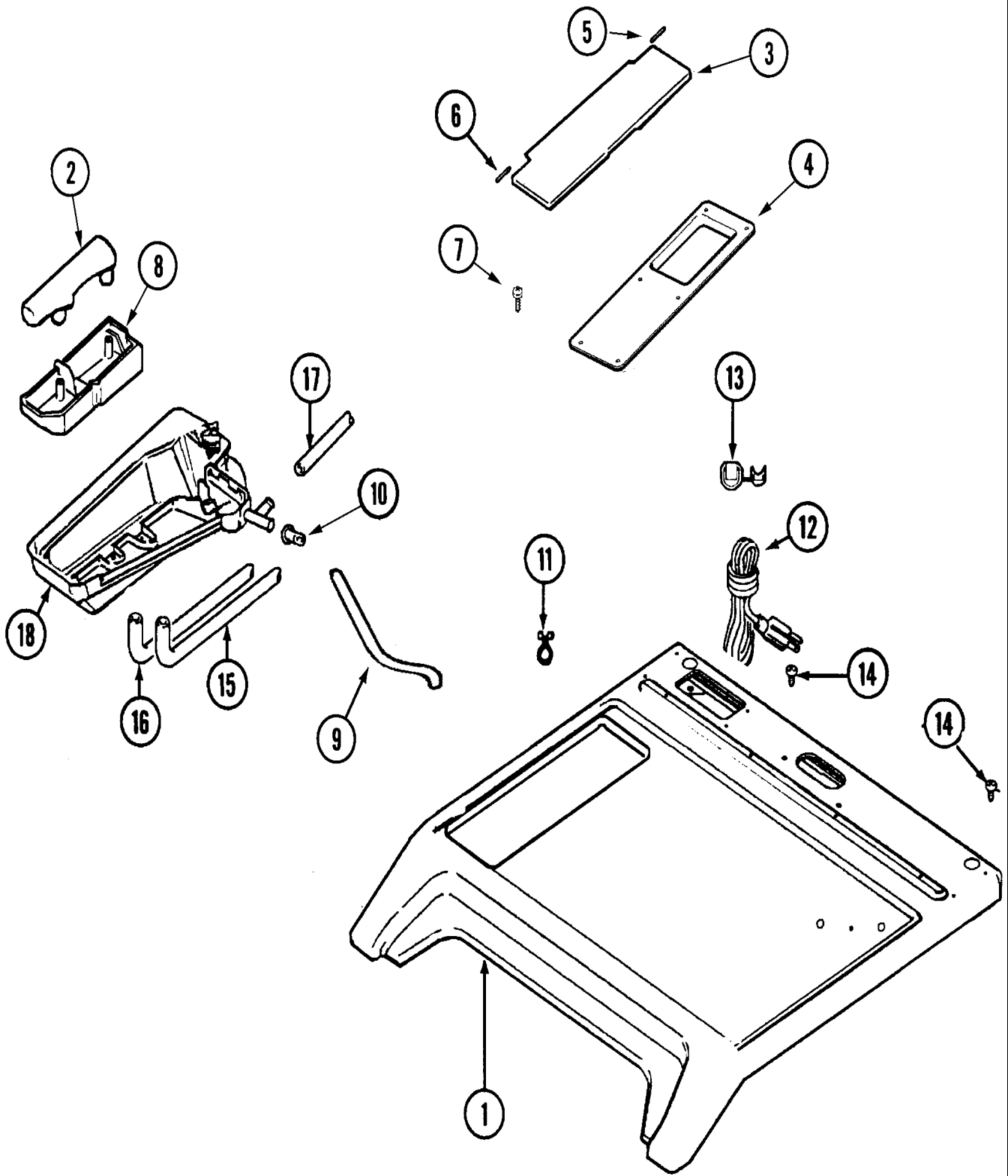

Section: CABINET-FRONT

MAH21 1 P4

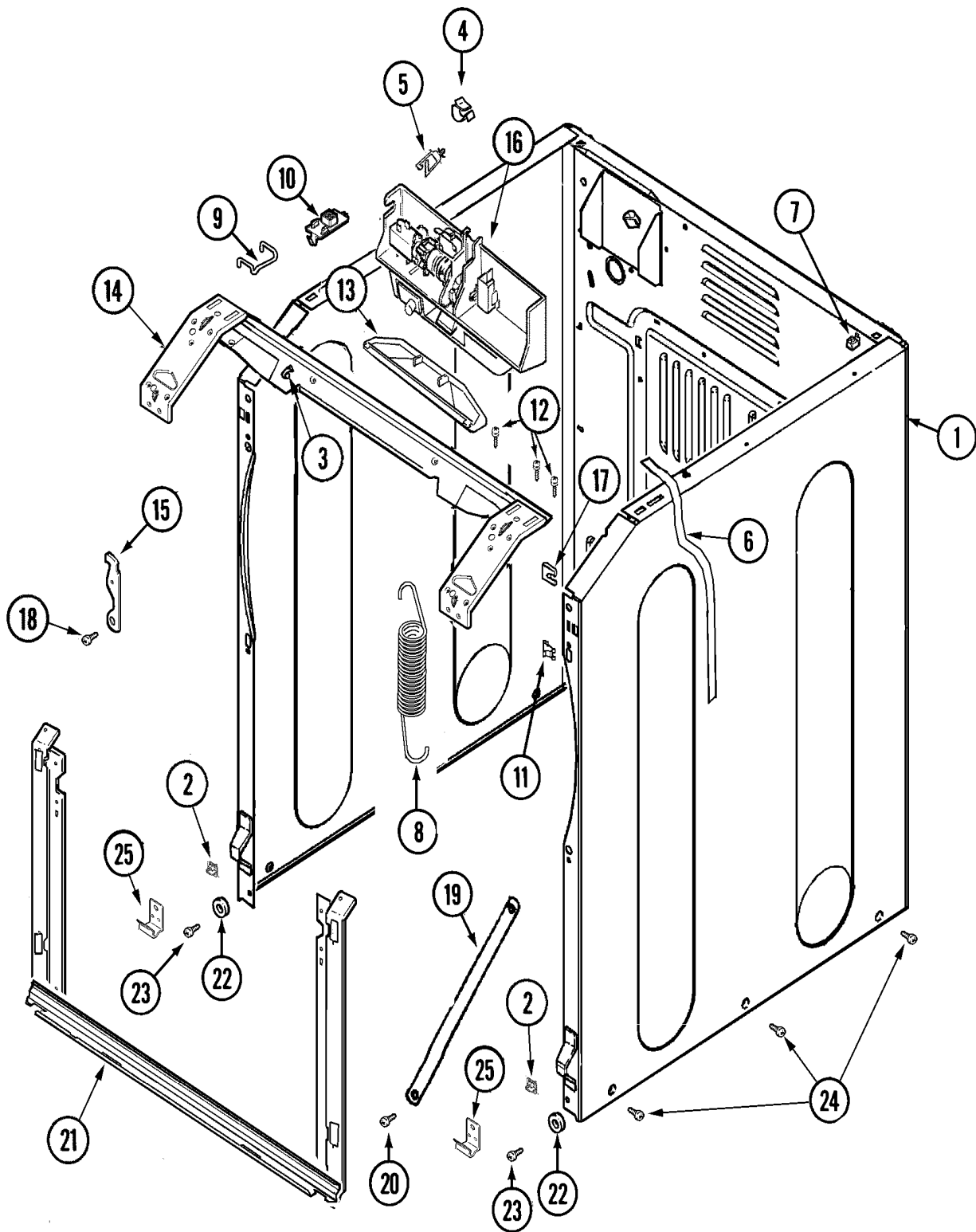

Section: DOOR & FRONT PANEL

MAH21 1 P5

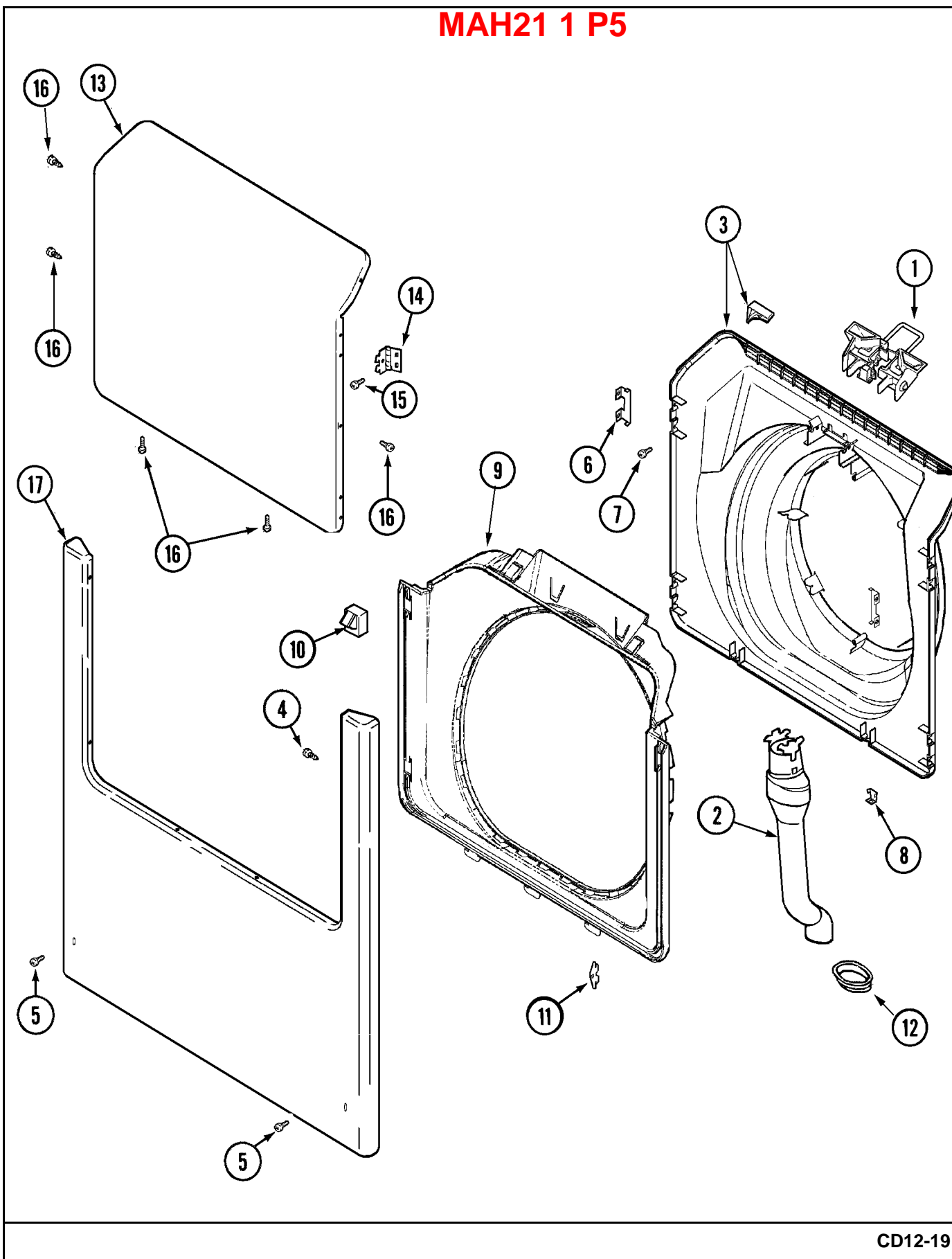

Section: CABINET-REAR

MAH21 1 P6

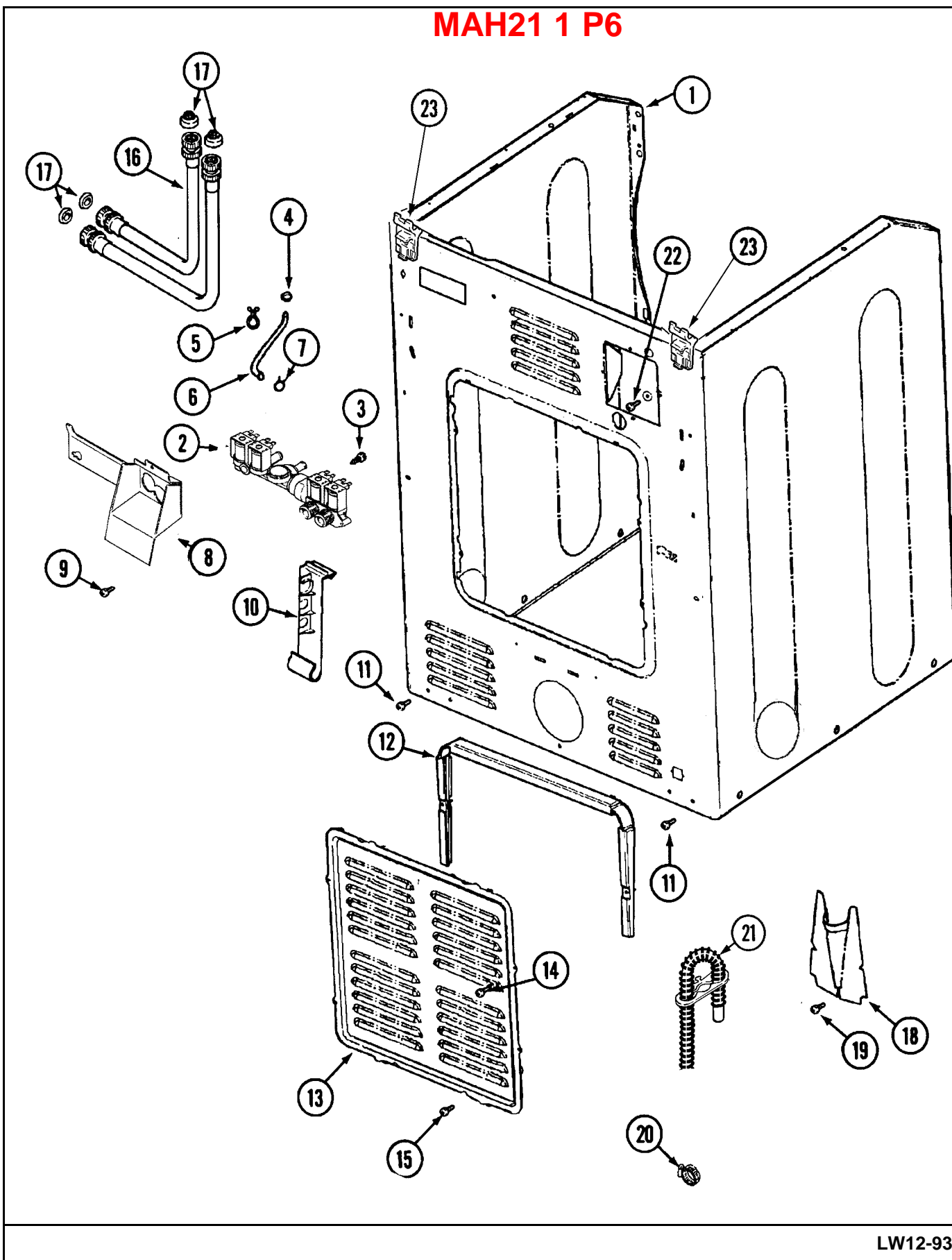

Section: OUTER TUB

MAH21 1 P7

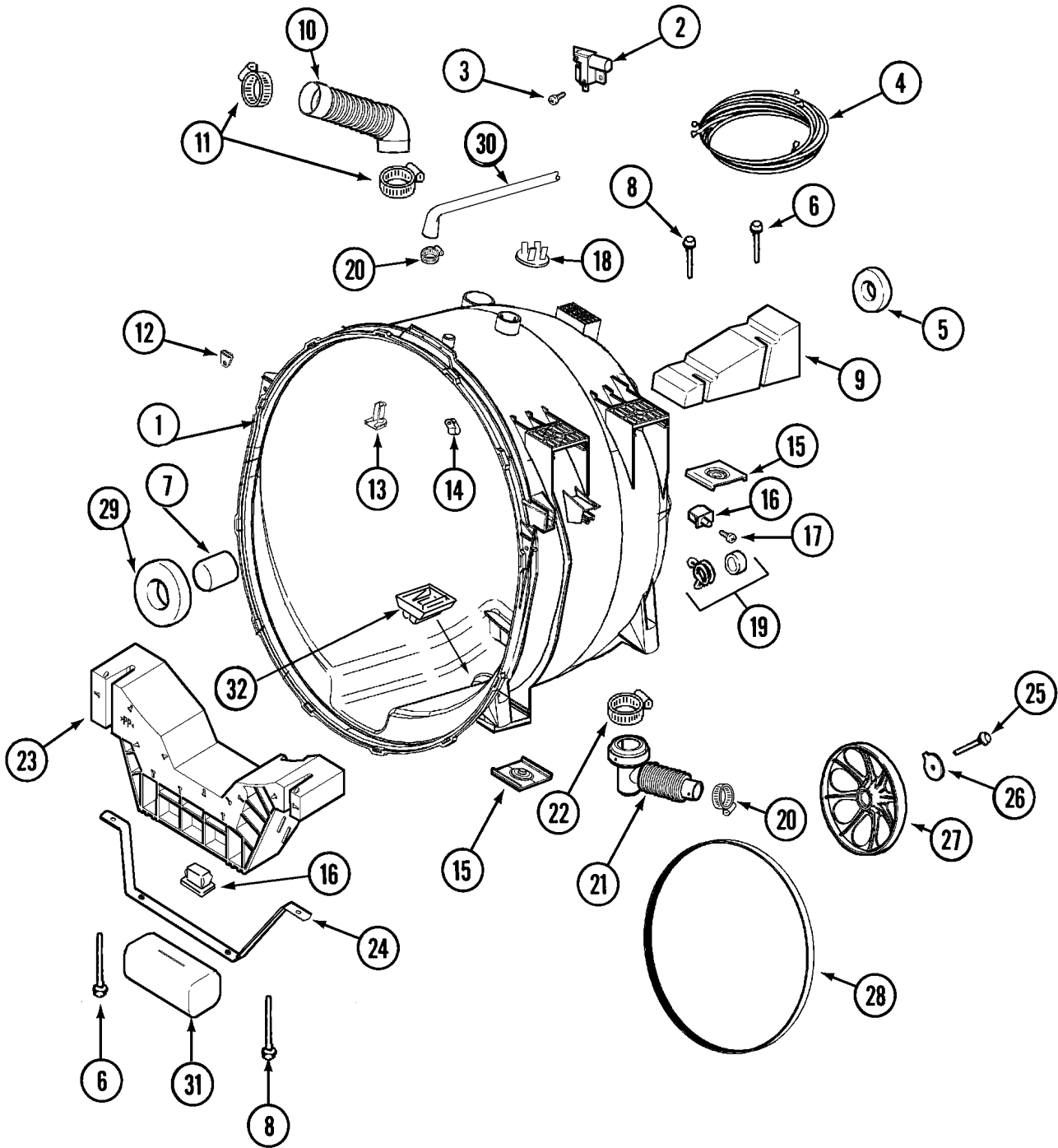



Section: SPINNER ASSEMBLY & OUTER TUB COVER

MAH21 1 P8

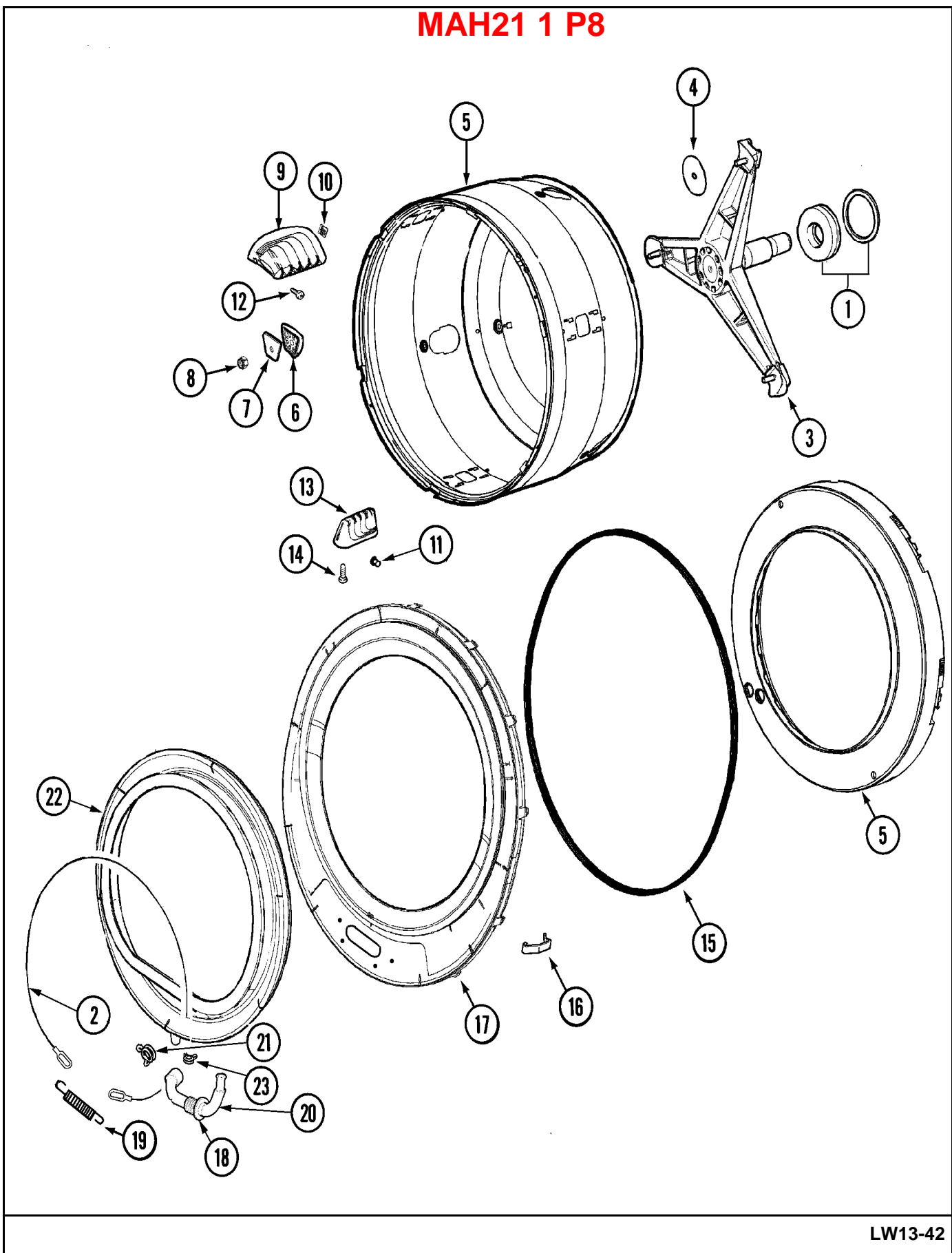

Section: BASE

MAH21 1 P9

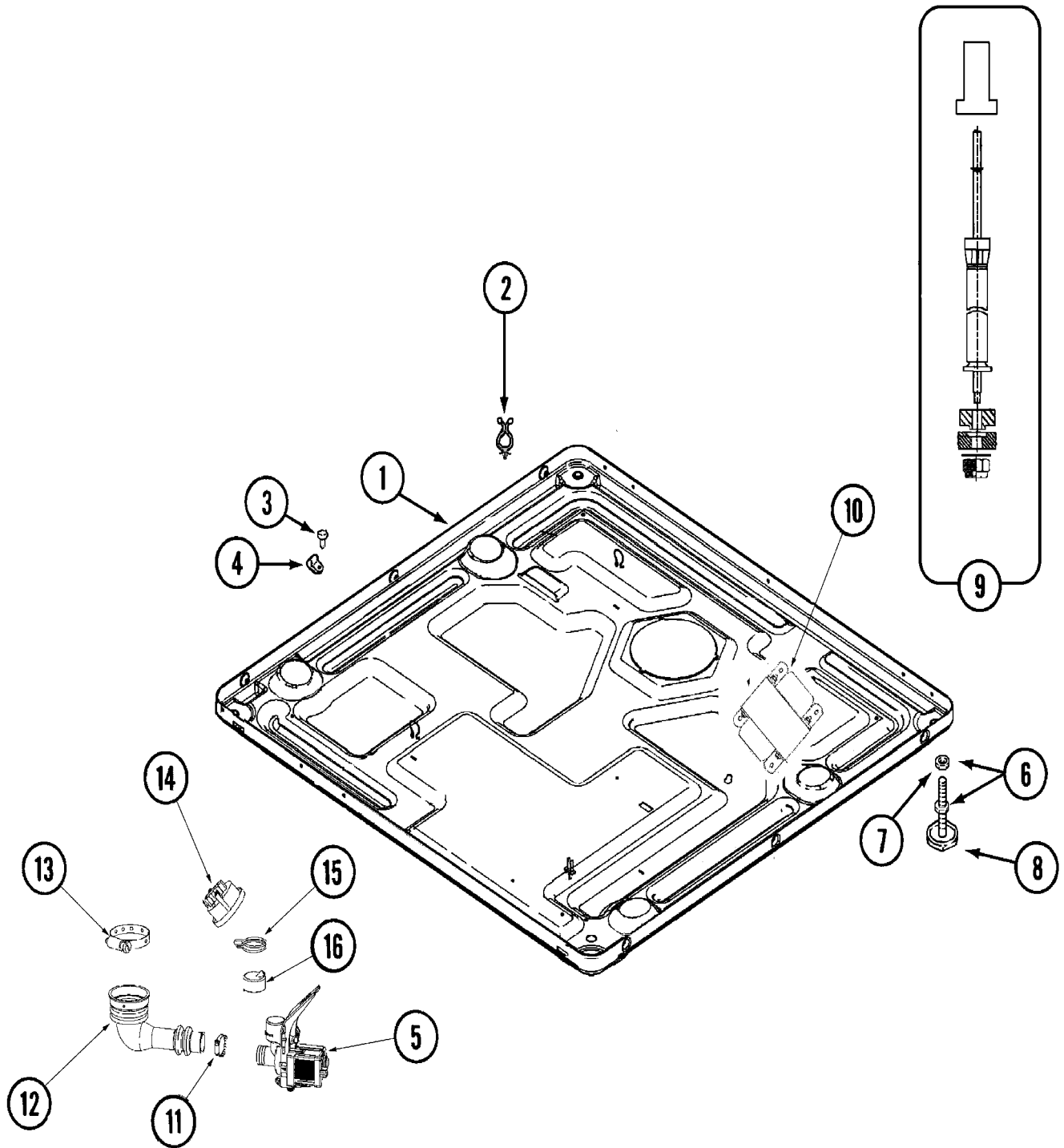

Section: WIRING INFORMATION

MAH21 1 P10

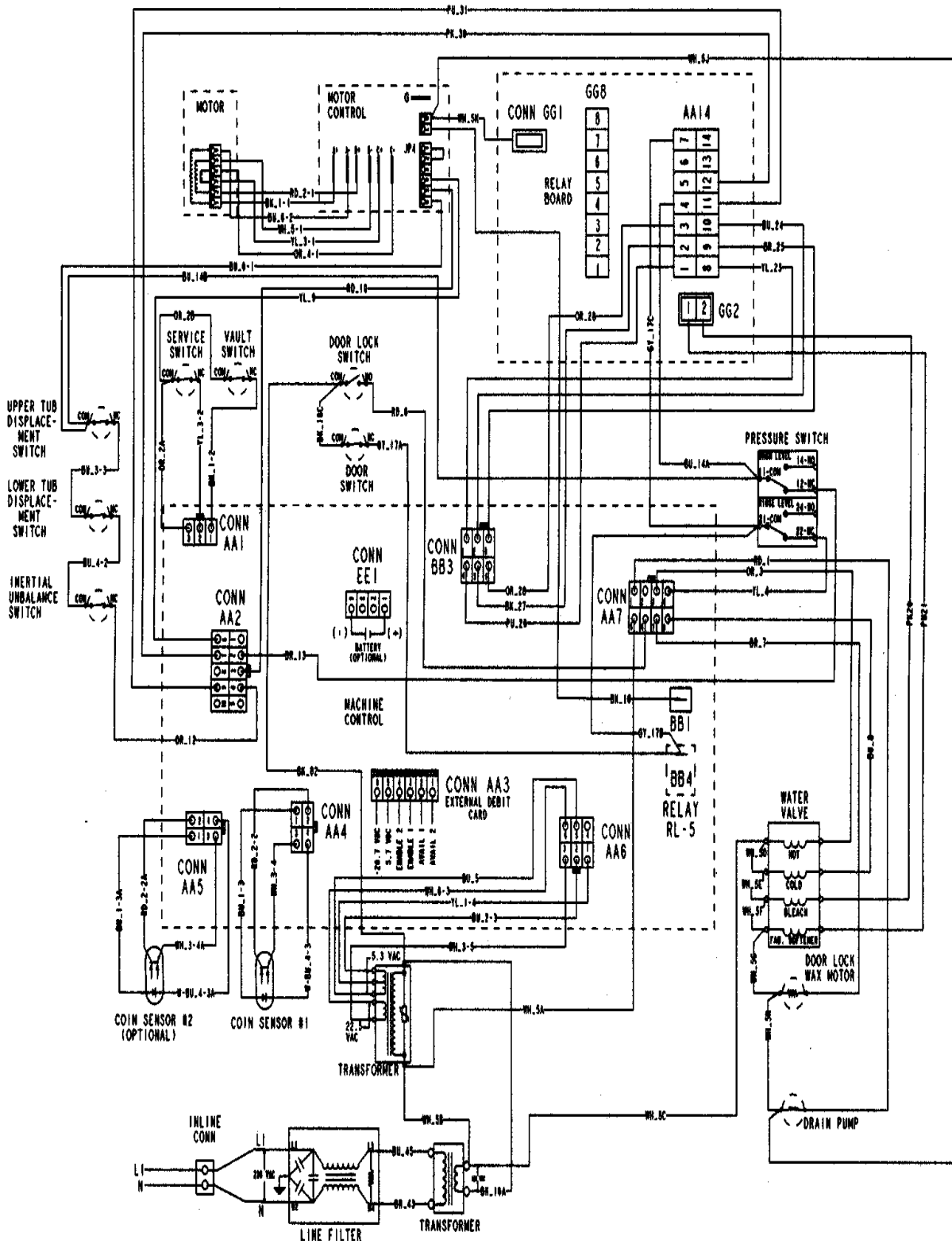



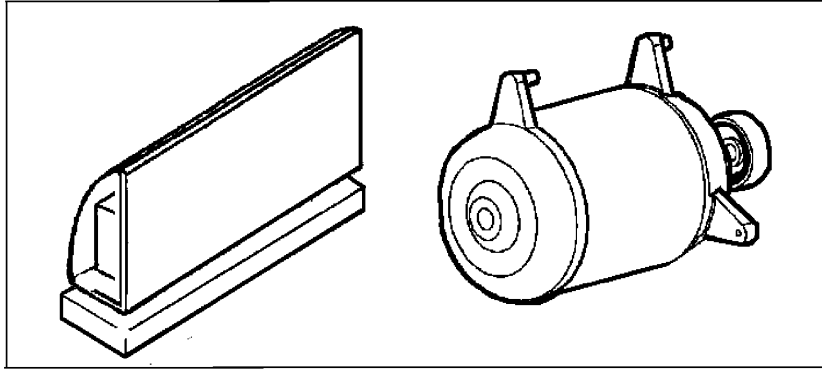

Section: MOTOR & MOTOR CONTROL

**MAH21 1 P11**

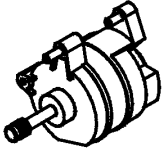
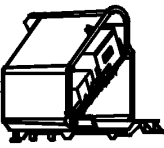
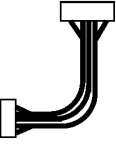
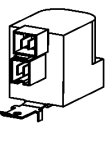
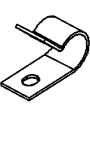

1

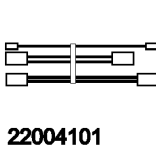
ITEM 1  
KIT CONTAINS:

 <p>120002040 MOTOR W/ISOLATORS</p>	 <p>22004046 MOTOR CONTROL BOARD</p>	 <p>22004047 MOTOR HARNESS</p>	 <p>22003854 AC LINE FILTER</p>	 <p>22004102 "P" CLIPS (2)</p>	 <p>22002300 SCREW "P" CLIPS TO MOTOR</p>	 <p>22004101 LOWER JUMPER WIRE HARNESS</p>	 <p>22004103 SCREW GROUND</p>
--	---	---	--	---	--	---	--

(SEE TEXT FOR ITEMS 2, 3, 4 AND 8)

