

**Repair
Parts
List**

MODEL NUMBER
A25CS

**WASHER
A25CS**

When requesting service or ordering parts, always provide the following information:

- Product Type
- Part Number
- Model Number
- Part Description

MAYTAG®

©2005 Maytag Services

MODEL A25CS

CS CONTROL PANEL, TOP COVER

& LID SWITCH

PRIOR TO SERIES 12

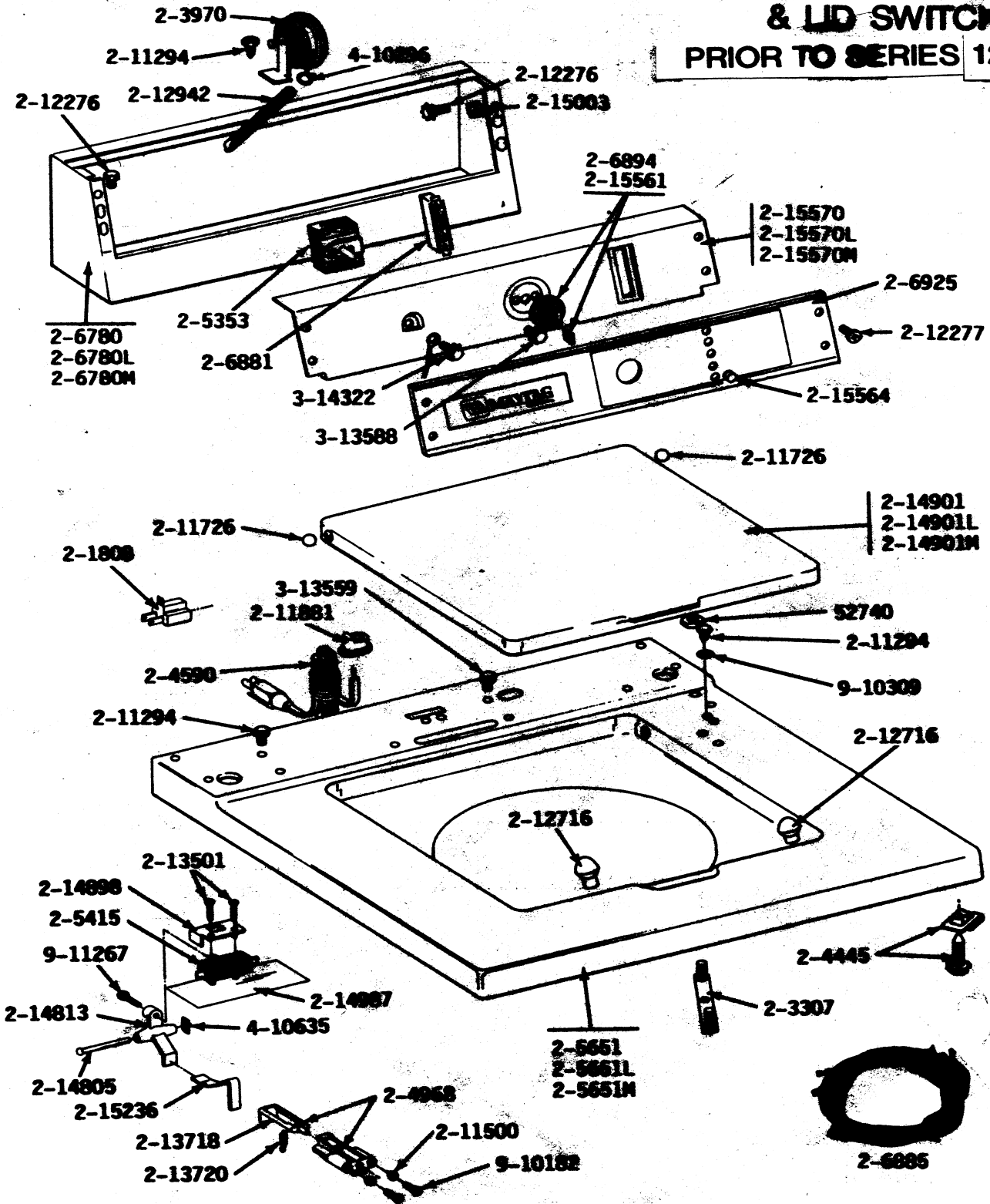

A25CS P2

MODEL A25CS

CS CONTROL PANEL, TOP COVER

**& LID SWITCH
SERIES 12**

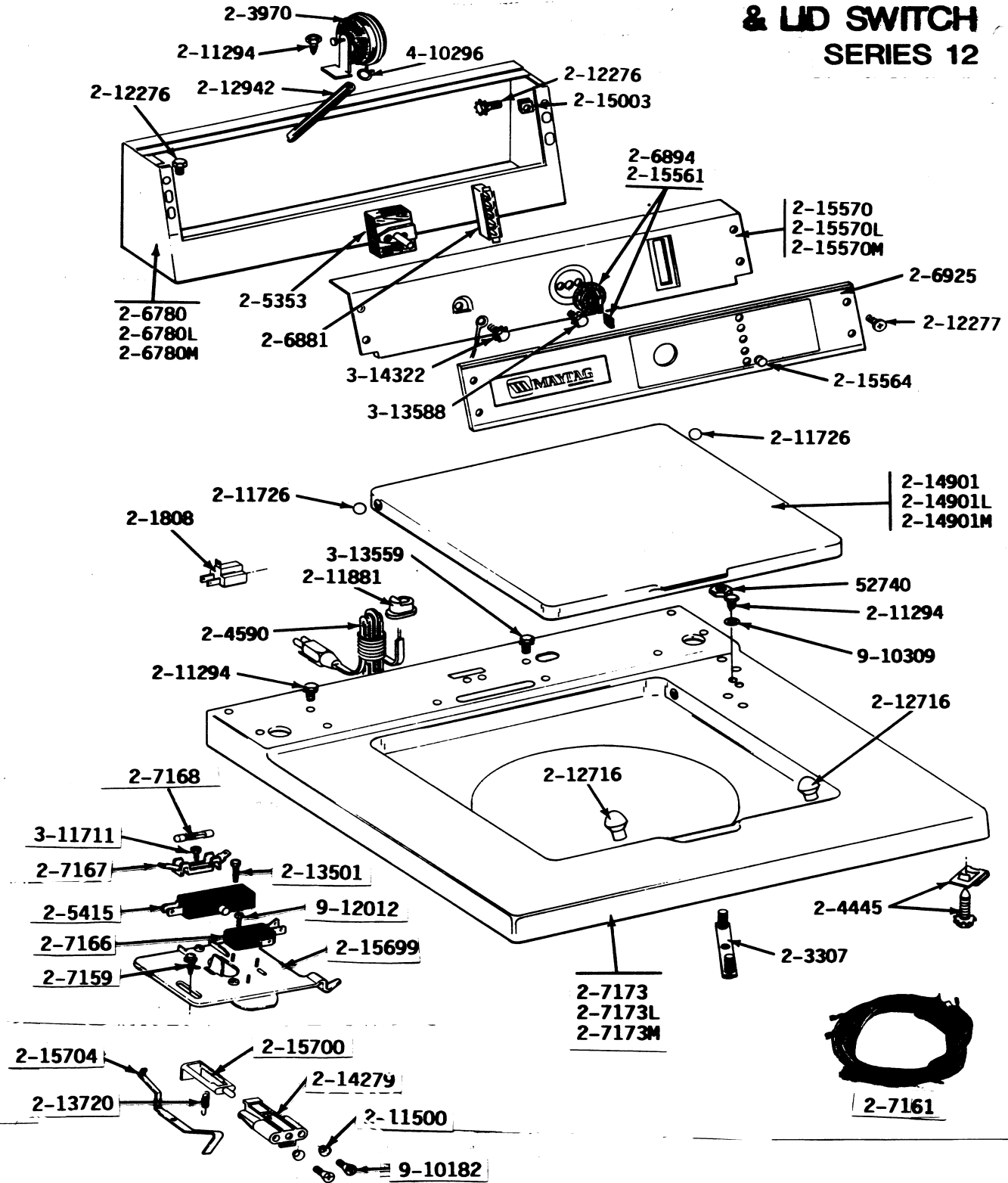

Section: CONTROL CENTER

A25CS P3

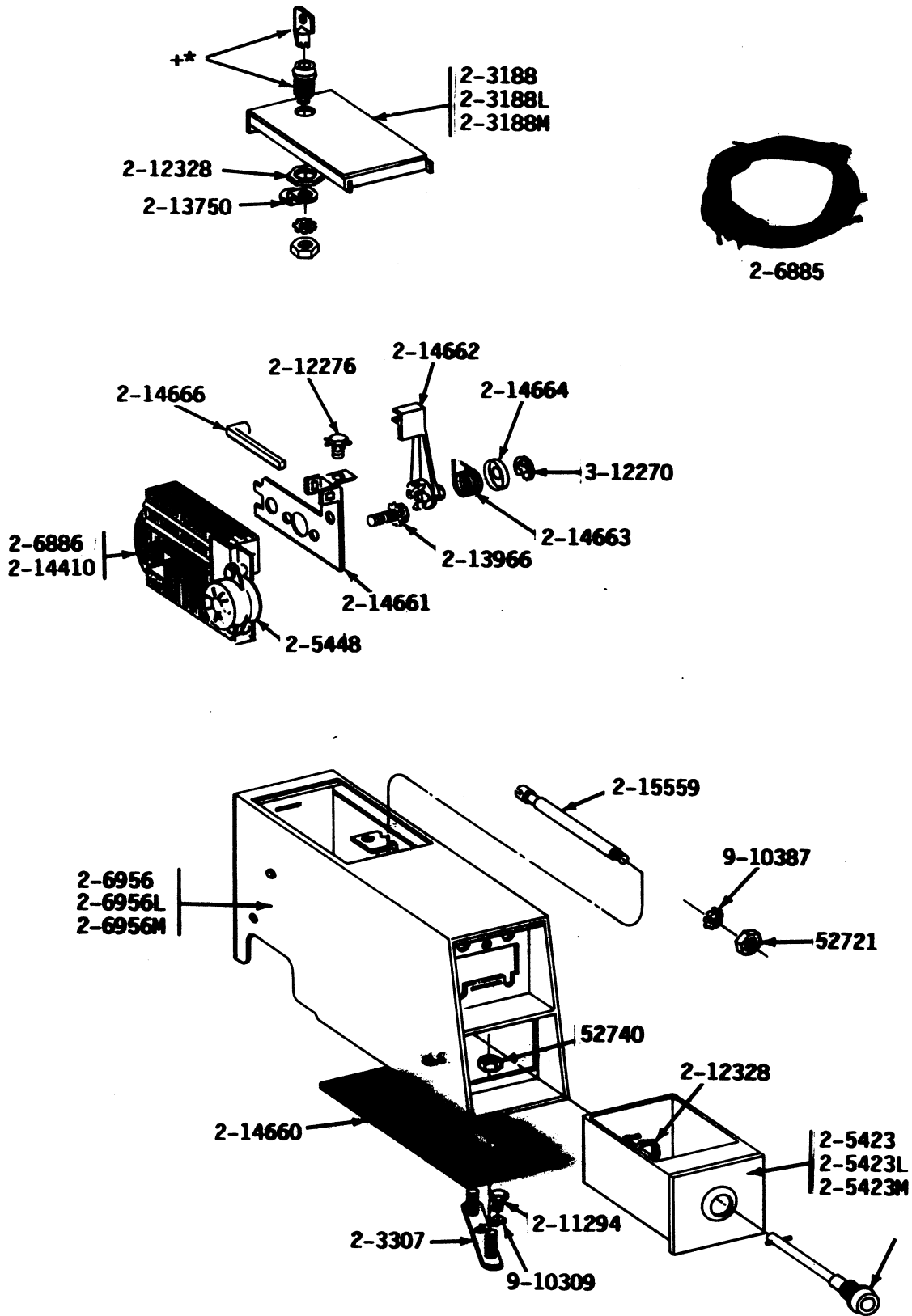

Section: MAYTAG COIN SLIDE

A25CS P4

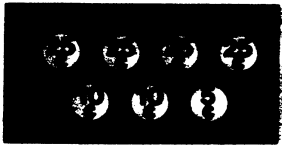

2-14648

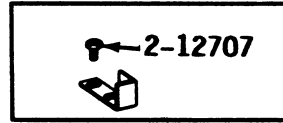

2-5469

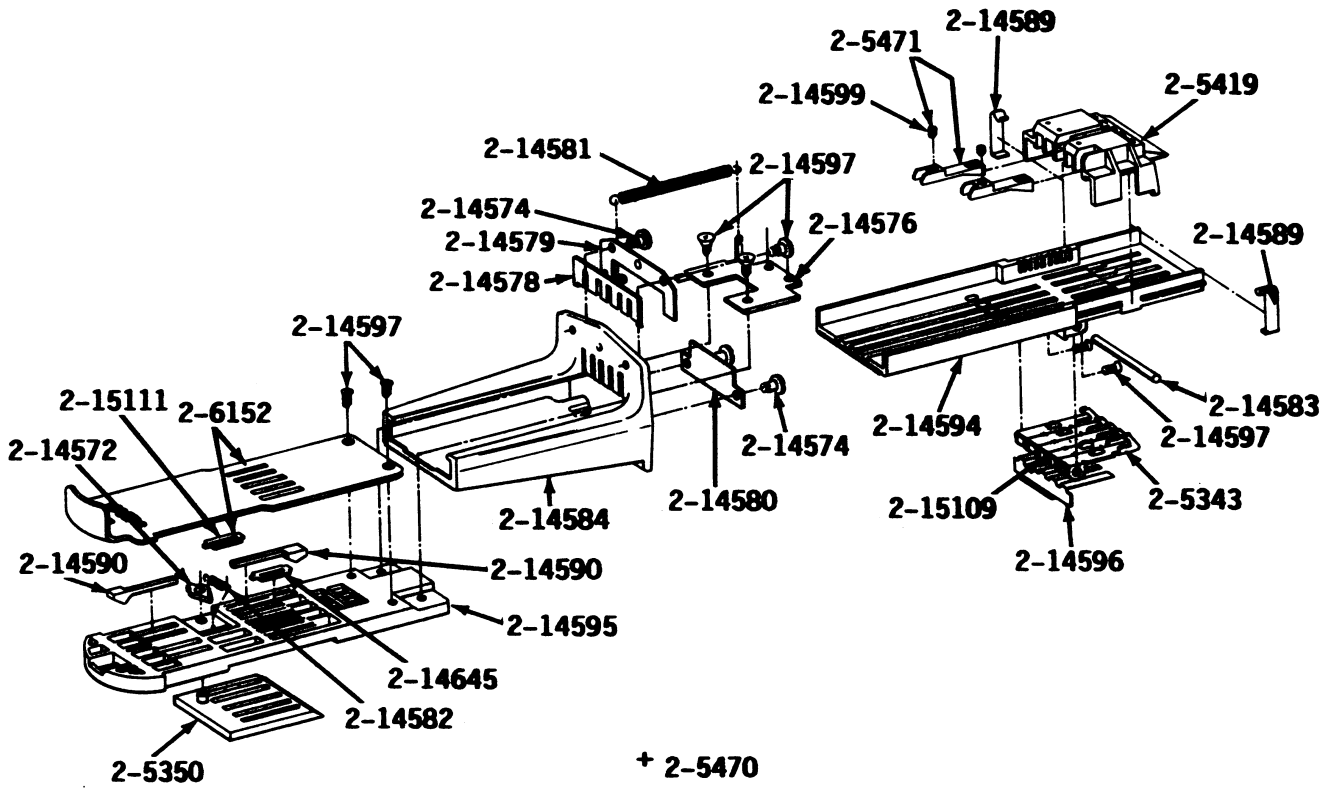

+ 2-5470
Maytag Coin Slide
Complete

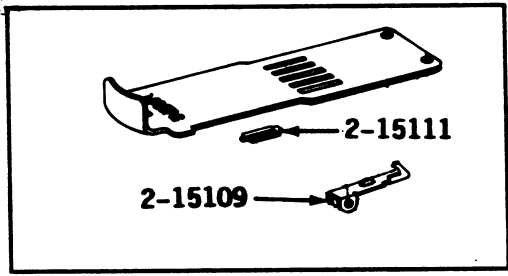

2-6152

Section: CABINET, WATER VALVE, HOSES & FRNT PANEL

A25CS P5

ALL MODELS

CABINET, WATER VALVE, HOSES AND FRONT PANEL

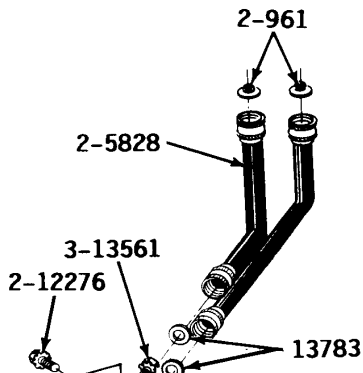

ACCESSORY HOSES

- 2-2860 5 ft. (1.51m) Straight Ends
- 2-672 5 ft. (1.51m) 90° Elbow
- 2-688 6 ft. (1.82m) 90° Elbow
- 2-681 10 ft. (3.04m) 90° Elbow
- 59137 Drain hose - available per ft.
- 59141 Drain hose - carton of 50 ft.
- 2-2861 Box of 25 hoses - straight ends

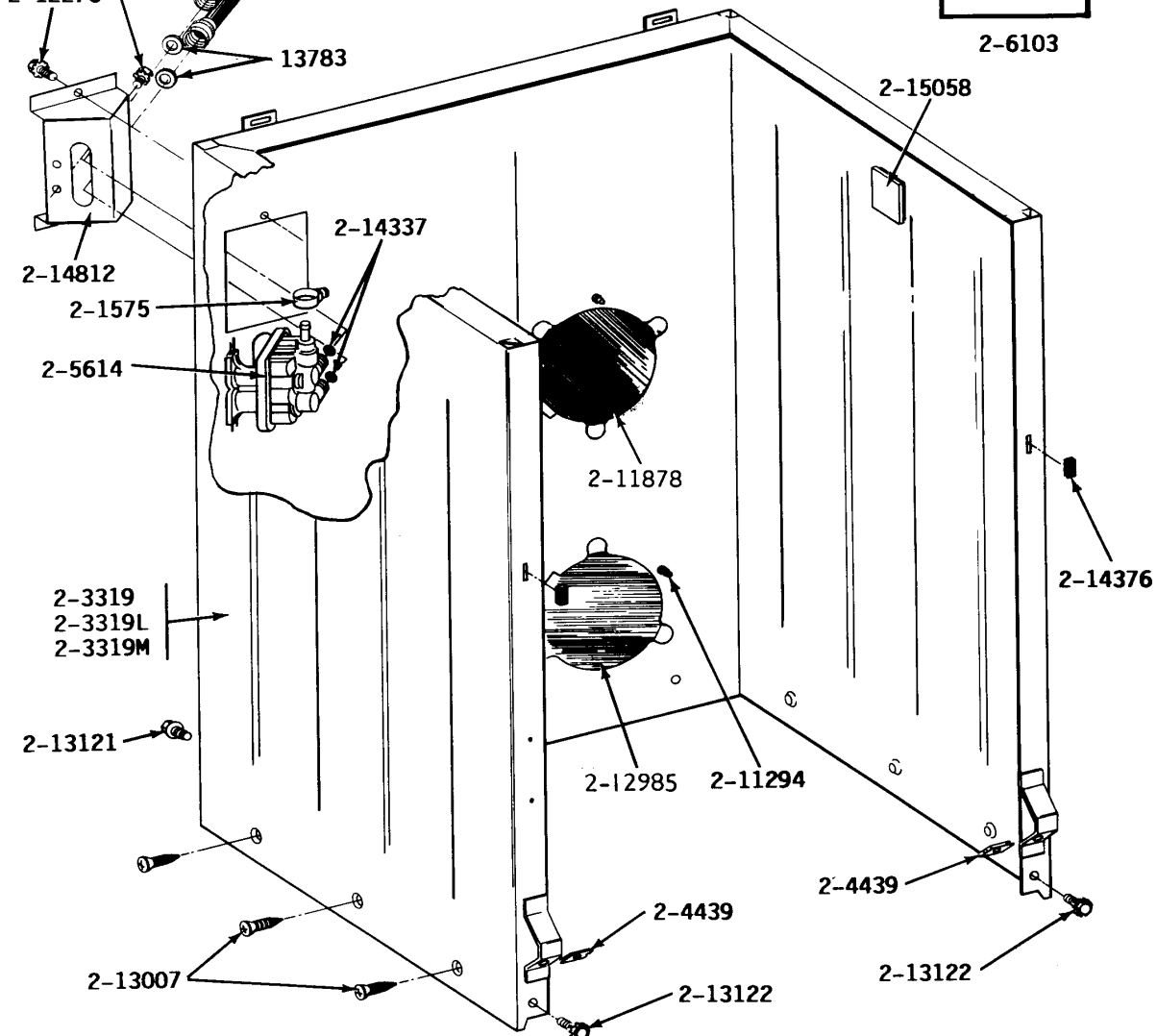
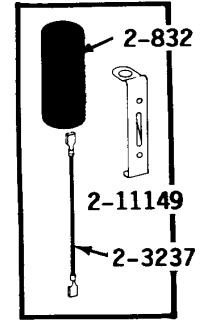

A25CS P6

ALL MODELS

TUB, AGITATOR, MOUNTING STEM

AND SEALS

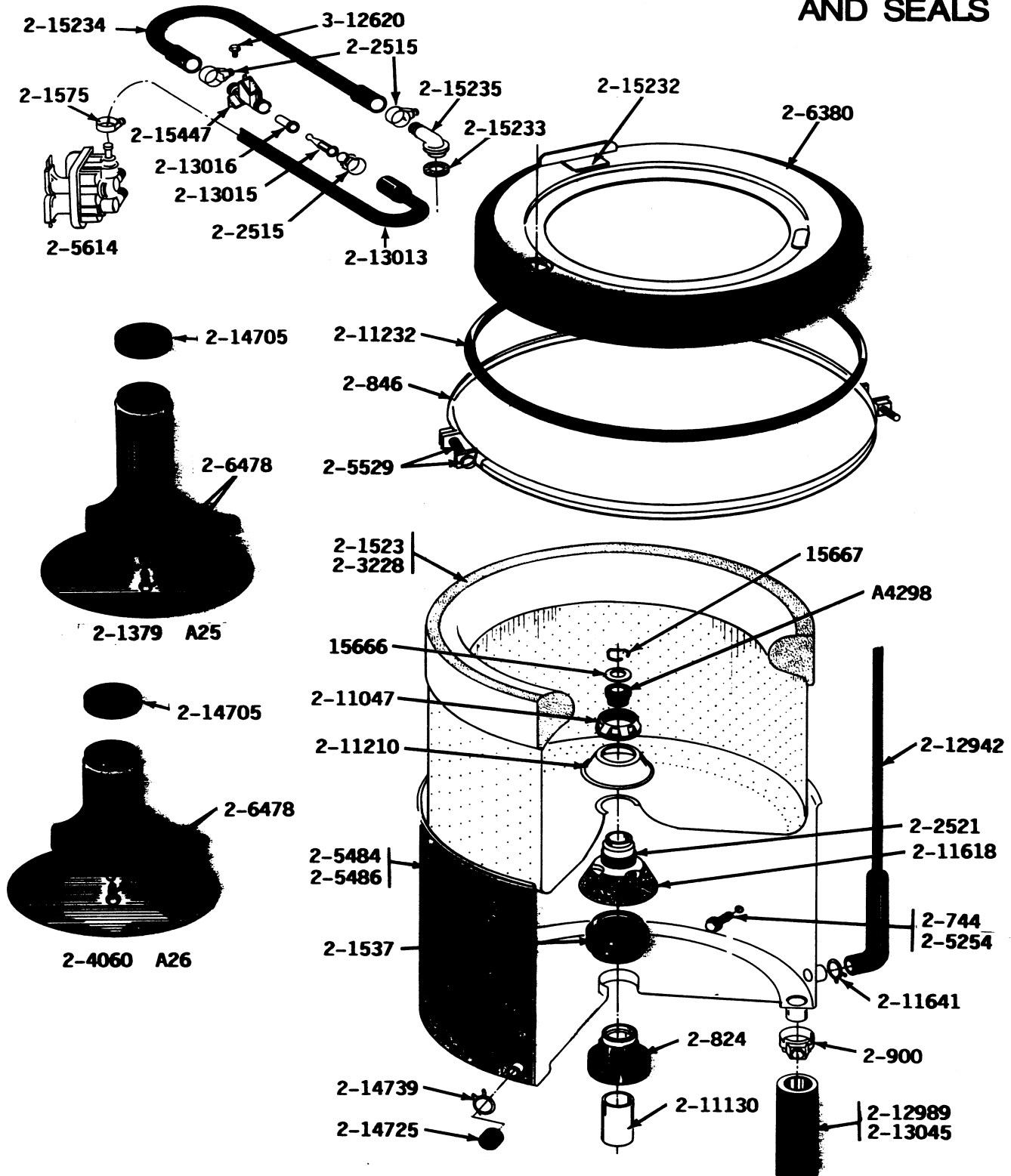

A25CS P7

ALL MODELS **TRANSMISSION**

PRIOR TO SERIES 10

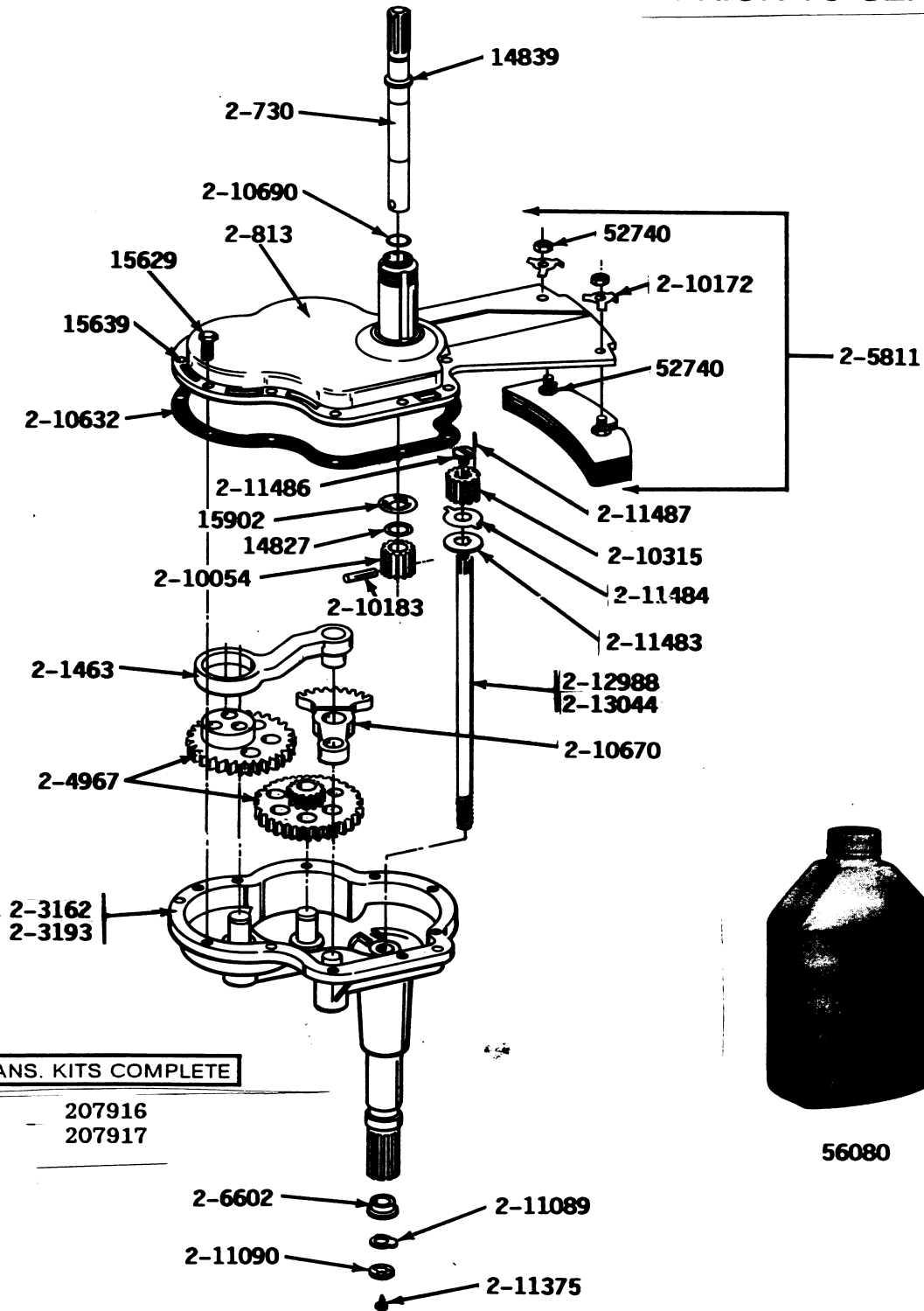

A25CS P8

ALL MODELS **ORBITAL TRANSMISSION**

SERIES 10

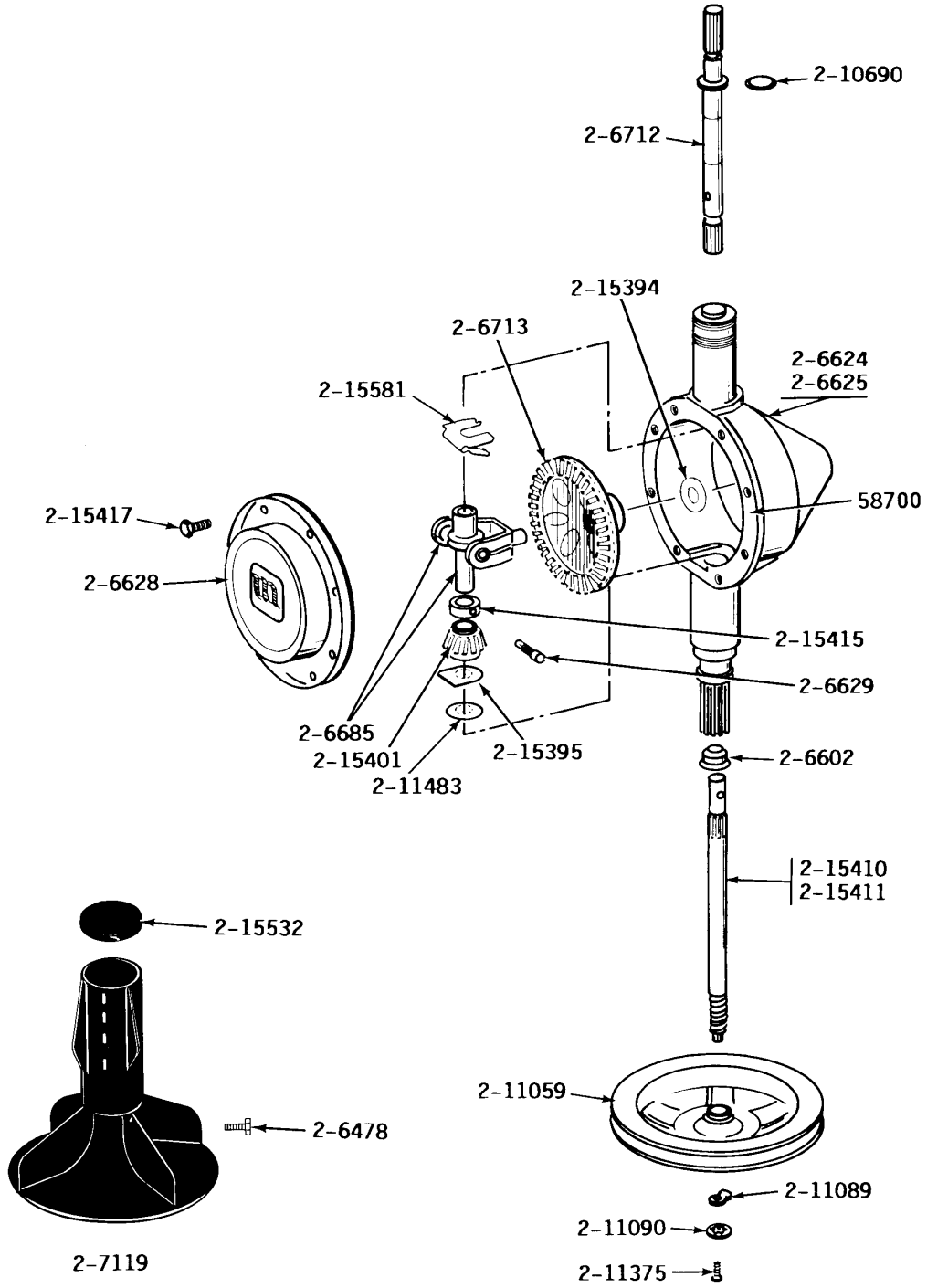

A25CS P9

ALL MODELS BASE, PUMP, MOTOR AND COMPONENTS

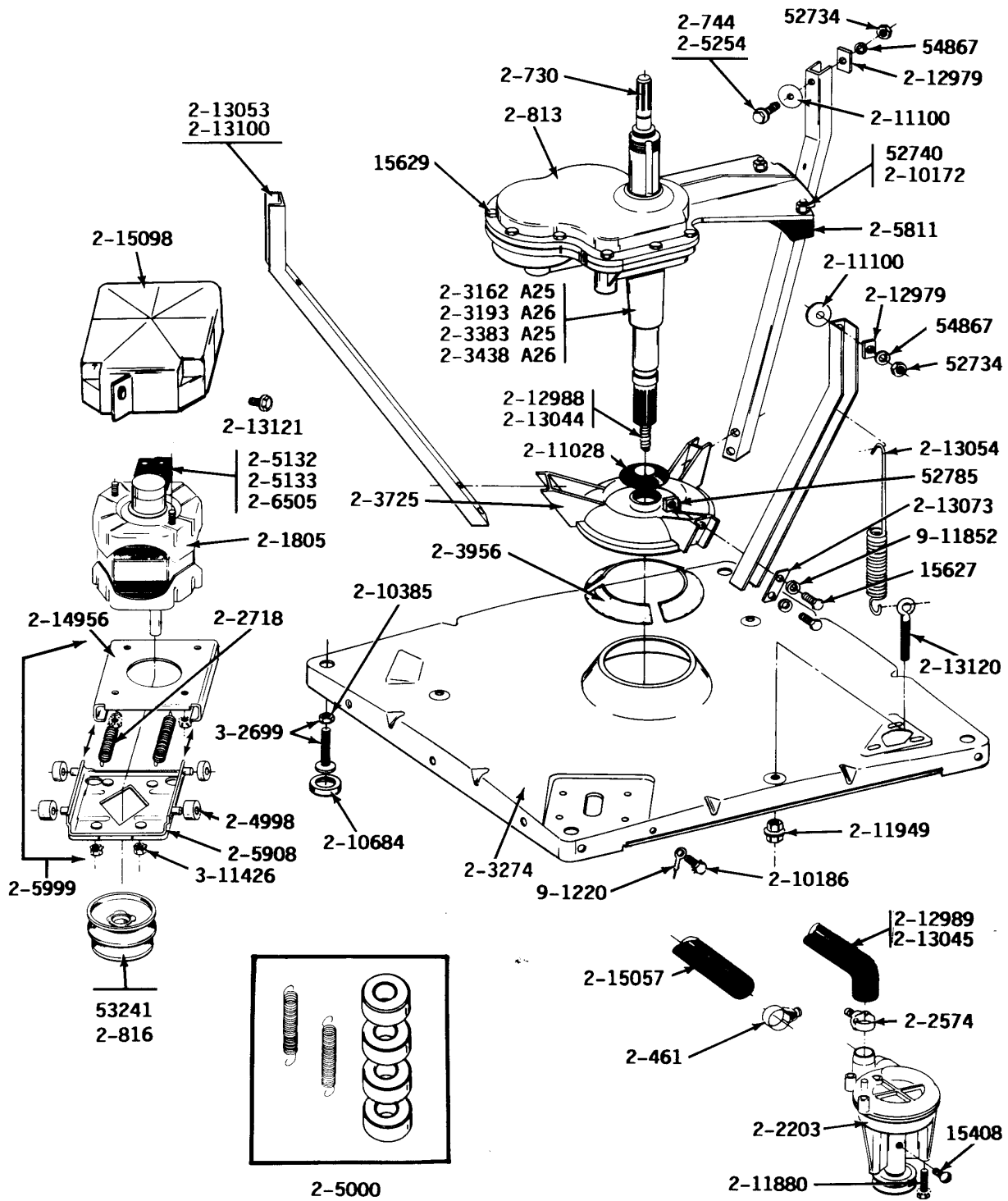

A25CS P10

ALL MODELS CLUTCH, BRAKE AND BELTS

